



Rewarding Learning

ADVANCED SUBSIDIARY (AS)
General Certificate of Education
2023

Centre Number

--	--	--	--	--

Candidate Number

--	--	--	--	--

Technology and Design

Assessment Unit AS 1

assessing

Systems and Control or
Product Design



[STE12]

STE12

FRIDAY 19 MAY, AFTERNOON

TIME

1 hour.

INSTRUCTIONS TO CANDIDATES

Write your Centre Number and Candidate Number in the spaces provided at the top of this page.

You must answer the questions in the spaces provided.

Do not write outside the boxed area on each page or on blank pages.

Questions which require drawing or sketching should be completed using an H.B. pencil.

All other questions must be completed using black ink only.

Do not write in pencil or with a gel pen.

Answer **both** questions in **either** Section A, B or C.

For all questions requiring calculations, show your working out.

INFORMATION FOR CANDIDATES

The total mark for this paper is 40.

Figures in brackets printed down the right-hand side of pages indicate the marks awarded to each question or part question.

13429



36STE1201

Section A

Electronic and Microelectronic Control Systems

Answer **both** questions in this section.

- 1 (a) **Fig. 1** shows a partially developed RC timing circuit where the capacitor C is charged when the switch Sw1 is closed.

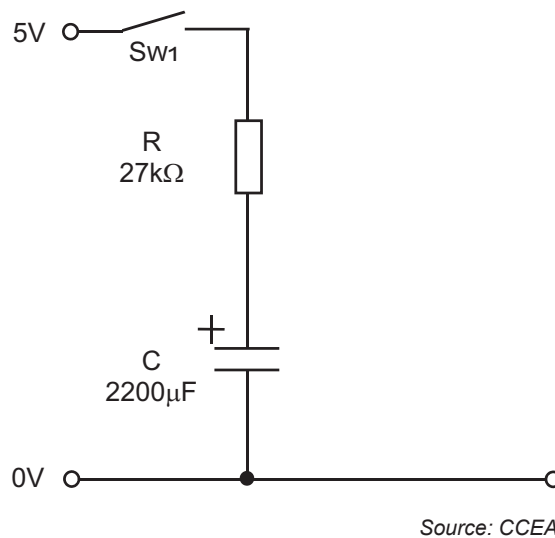

Fig. 1

- (i) Using the component values shown in **Fig. 1** calculate the time constant for the circuit.

Answer _____ seconds [2]

- (ii) Explain **one** reason (other than cost) for utilising an electrolytic capacitor rather than a non-polarised capacitor for the timing circuit shown in **Fig.1**.

_____ [2]



(iii) Two further developments are to be made to the circuit in **Fig. 1**.

- A means of allowing the operator of the circuit to switch between the time constant in **Fig. 1** and an alternative time constant which should be twice the duration.
- A means of discharging the capacitor (when switch Sw1 is opened) at a safe and controlled rate.

Show how these developments could be implemented by completing the circuit in **Fig. 2**, adding appropriate circuit symbols and component values.

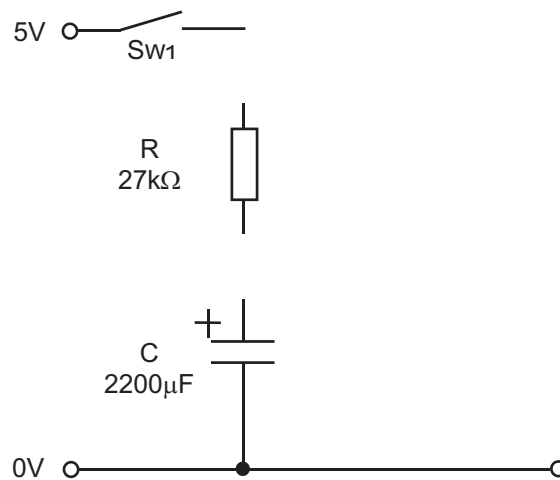

Source: CCEA

Fig. 2

[5]



(b) Fig. 3 shows an incomplete 555 timer circuit. The connection labelled 2 is the trigger pin on the 555 timer.

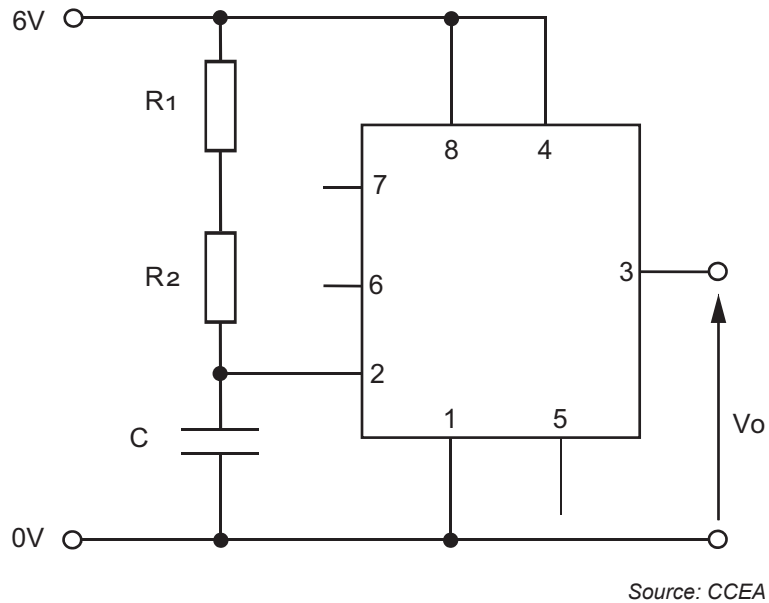

Fig. 3

(i) Explain the function performed by the trigger pin on a 555 timer.

[2]

(ii) State the name of the pin on the 555 timer that is labelled 7 in Fig. 3.

[1]

(iii) Complete the connections for pins 6 and 7 in Fig. 3 to enable the circuit to function as an astable system.

[2]



(c) The output (V_o) from an astable timer circuit is shown as a graph in **Fig. 4**.

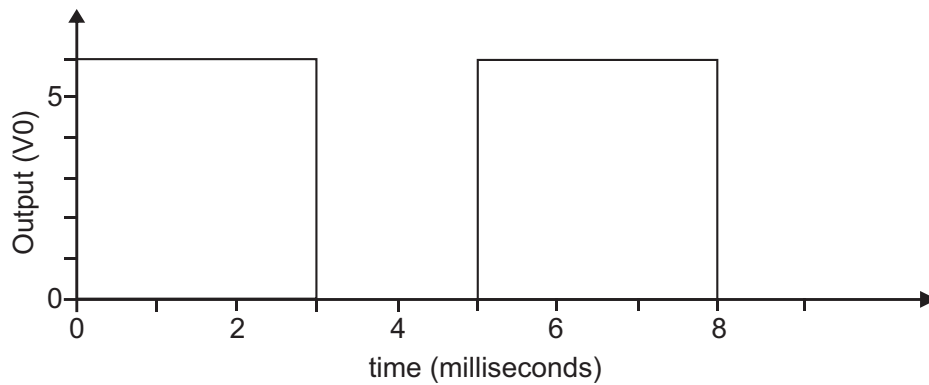

Source: CCEA

Fig. 4

(i) From the graph shown in **Fig. 4** determine the mark/space ratio of the output V_o .

Answer _____ [1]

(ii) Calculate the frequency of the output of an astable circuit based on a 555 timer if $R_1 = 10\text{ k}\Omega$, $R_2 = 20\text{ k}\Omega$ and $C = 470\text{ nF}$.

Answer _____ Hz [3]

[Turn over



(iii) The output from the circuit shown in **Fig. 3** is to be connected to two LEDs as shown in **Fig. 5**. If each LED operates at a forward voltage of 2.2V and a current of 15mA, calculate the required value for the protective resistor R.

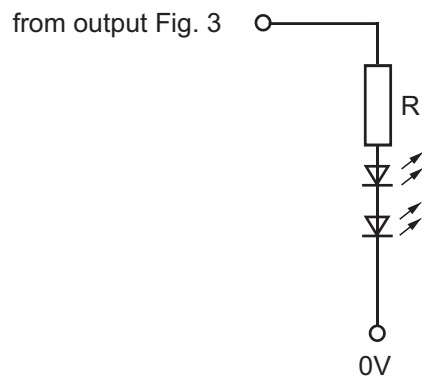

Source: CCEA

Fig. 5

Answer _____ Ohms [2]



2 (a) A motor control circuit is shown in Fig. 6.

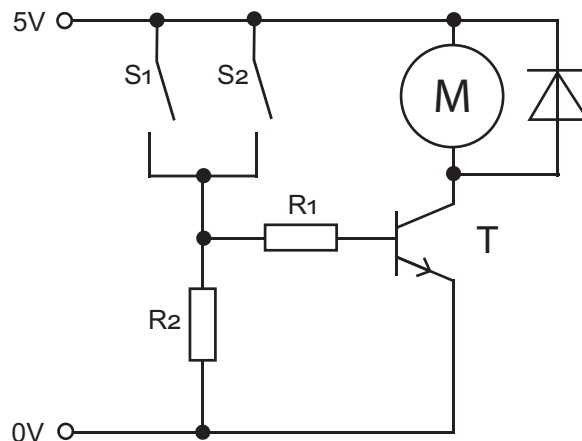

Source: CCEA

Fig. 6

(i) State the type of logic control achieved by the arrangement of the switches S1 and S2 in Fig. 6.

_____ [1]

(ii) Explain why the resistor R2 has been included in the circuit shown in Fig. 6.

 _____ [2]

(iii) The npn transistor T, used to control the motor in Fig. 6 has a current gain (h_{fe}) of 40 and a base emitter voltage (V_{be}) of 0.7V. If the collector current I_c (max) is 250 mA, calculate the required value of the protective resistor R1.

Answer _____ Ohms [3]

[Turn over



- (iv) Calculate the power dissipated by the motor in **Fig. 6** if it has an operating current of 200 mA (Assume there is no voltage drop across the emitter and collector of the transistor).

Answer = _____ W [2]

- (b) The motor control circuit in **Fig. 6** is to be developed to one based on logic gates. A systems diagram for the proposed developed circuit is shown in **Fig. 7**.

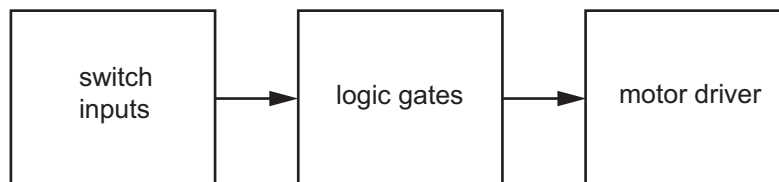

Source: CCEA

Fig. 7

- (i) State if the proposed system represented in **Fig. 7** can be analysed as either continuous or on/off and justify your answer.

Answer _____ [1]

Justification _____

_____ [2]



- (ii) The logic circuit for the proposed system shown in **Fig. 7** consists of an arrangement of NAND gates. Draw the circuit symbol for a NAND gate and complete the truth table in **Fig. 8** below.

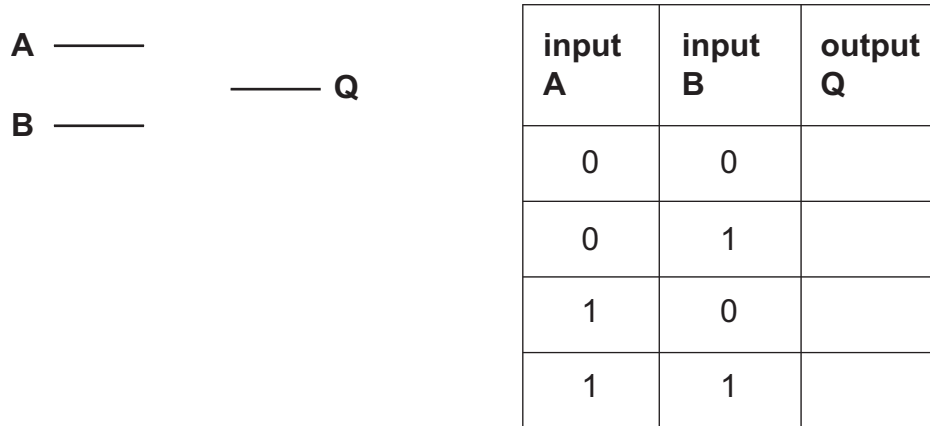

Fig. 8

[2]

- (iii) The logic circuit for the proposed system shown in **Fig. 7** is to be based on NAND gates arranged to make an SR flip flop. The flip flop will in turn provide a latching action. Explain what is meant by the term latching in relation to electronic systems.

_____ [2]

[Turn over



(iv) Complete the circuit diagram on **Fig. 9** below for the proposed system shown in **Fig. 7** to control the motor as follows:

- A latching action will be maintained by an SR flip flop made from NAND gates.
- The motor will latch on when a push to break switch is momentarily pressed (set).
- The motor will switch off when another push to break switch is momentarily pressed (reset).

Add a label to identify the set switch.

[5]

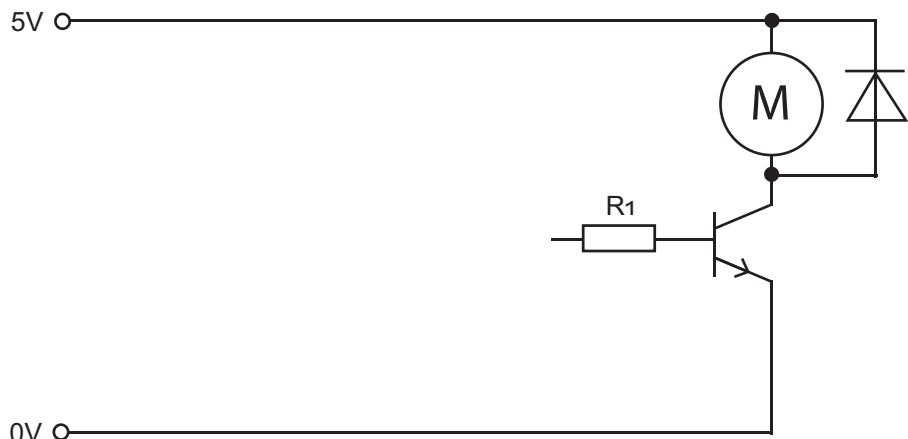

Source: CCEA

Fig. 9





BLANK PAGE

DO NOT WRITE ON THIS PAGE

(Questions continue overleaf)

13429

[Turn over



36STE1211

Section B

Mechanical and Pneumatic Control Systems

Answer **both** questions in this section.

- 3 **Fig. 10** shows an incomplete prototype system used to slice potatoes in a factory. The motor drives the gear and pulley system which in turn controls the movement of the conveyor belt to transport the potatoes into the hopper for slicing. Pneumatics controls the opening and closing of the feed hopper and the movement of potatoes in the hopper in preparation for them to be sliced.

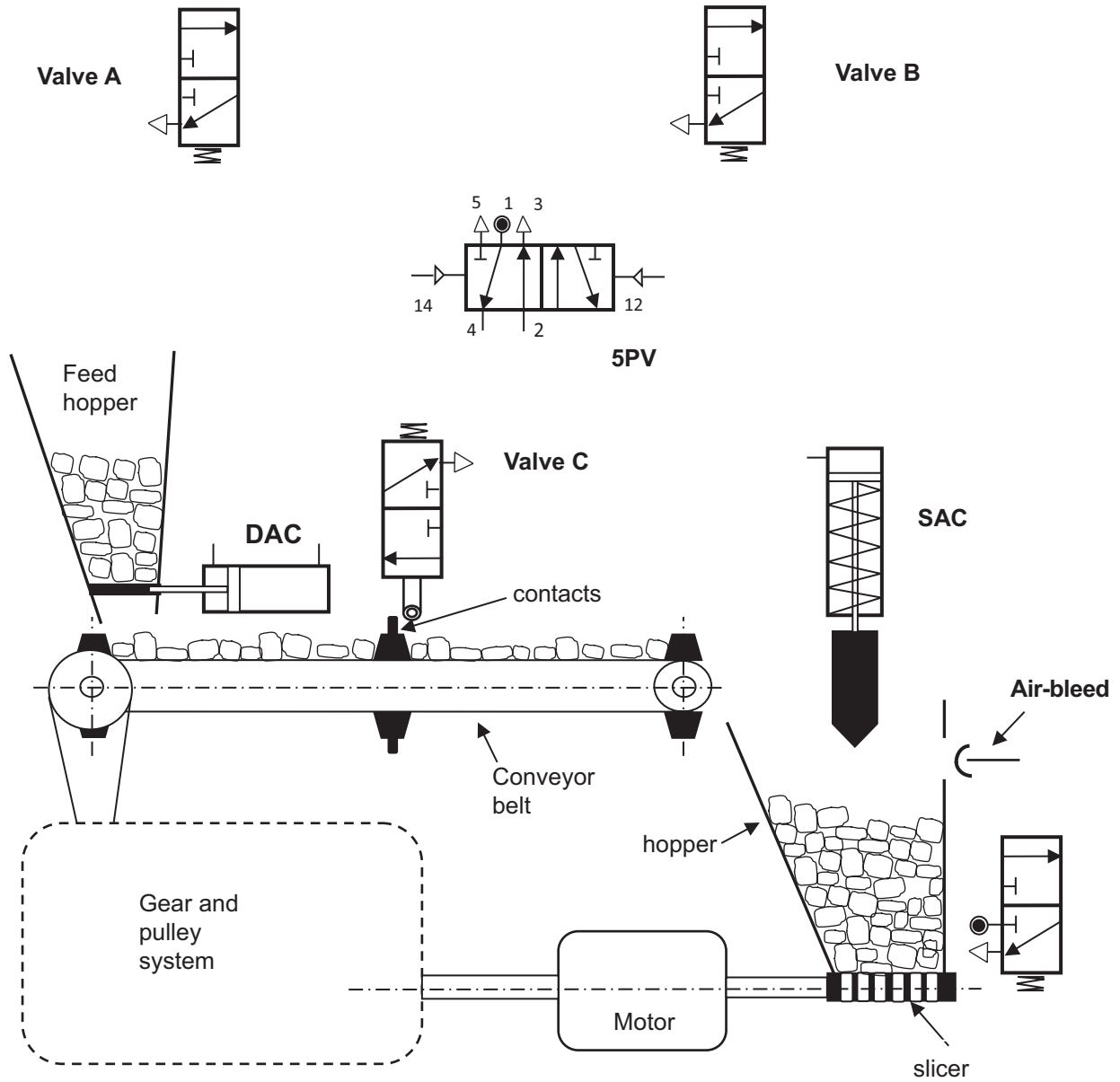

Fig. 10

Source: CCEA



(a) The incomplete potato slicer shown in **Fig. 10** uses a combination of a mechanical system and a pneumatic system.

Briefly outline **one** safety issue which arises when using a mechanical system and briefly outline **one** main procedure which could minimise this issue.

Safety issue _____
_____ [1]

Procedure _____
_____ [1]

[Turn over



(b) Fig. 11 shows the motor, gear and pulley system used to control the conveyor belt shown in Fig. 10.

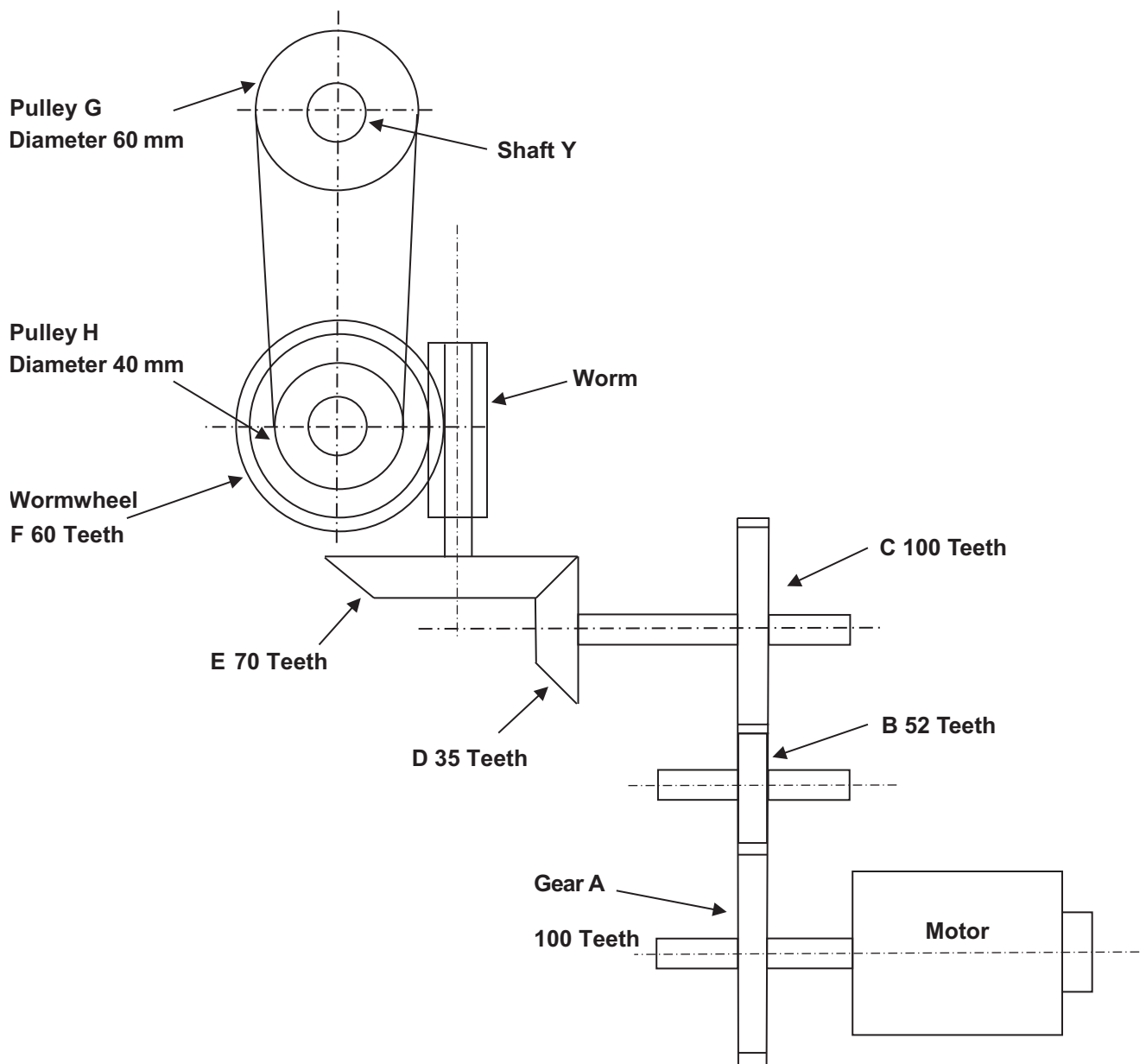

Source: CCEA

Fig. 11



(i) With reference to **Fig. 11** calculate the velocity ratio between **Gear A** and **Wormwheel F**.

Answer _____ [4]

(ii) Calculate the output speed at **Shaft Y** if the motor rotates at 720 rev/min.

Answer _____ rev/min [3]

[Turn over



(iii) During testing of the system, it was considered that the output speed at **Shaft Y** was too slow. After changing some of the gears and pulleys it was calculated that the system had an overall velocity ratio of 80 and a mechanical advantage of 64. Calculate the efficiency of the system.

Answer _____ % [2]

(c) To prevent slippage, the belt connecting **Pulley G** to **Pulley H** shown in **Fig. 11** is to be fitted with a self-adjusting jockey wheel. Using an annotated sketch, draw the main features of a self-adjusting jockey wheel.

[2]



(d) (i) Complete part of the pneumatic circuit in **Fig. 12** to enable the double acting cylinder (DAC) to instroke **slowly** following activation of the 5PV. The 5PV will only operate when valve A **AND** valve B are pressed. [3]

(ii) Complete the remaining part of the pneumatic circuit in **Fig. 12** to enable the DAC to outstroke when the air bleed is activated. In addition, valve C which is activated by the contacts on the conveyor belt in **Fig. 10**, will operate the single acting cylinder (SAC) only when the double acting cylinder is instroking. [4]

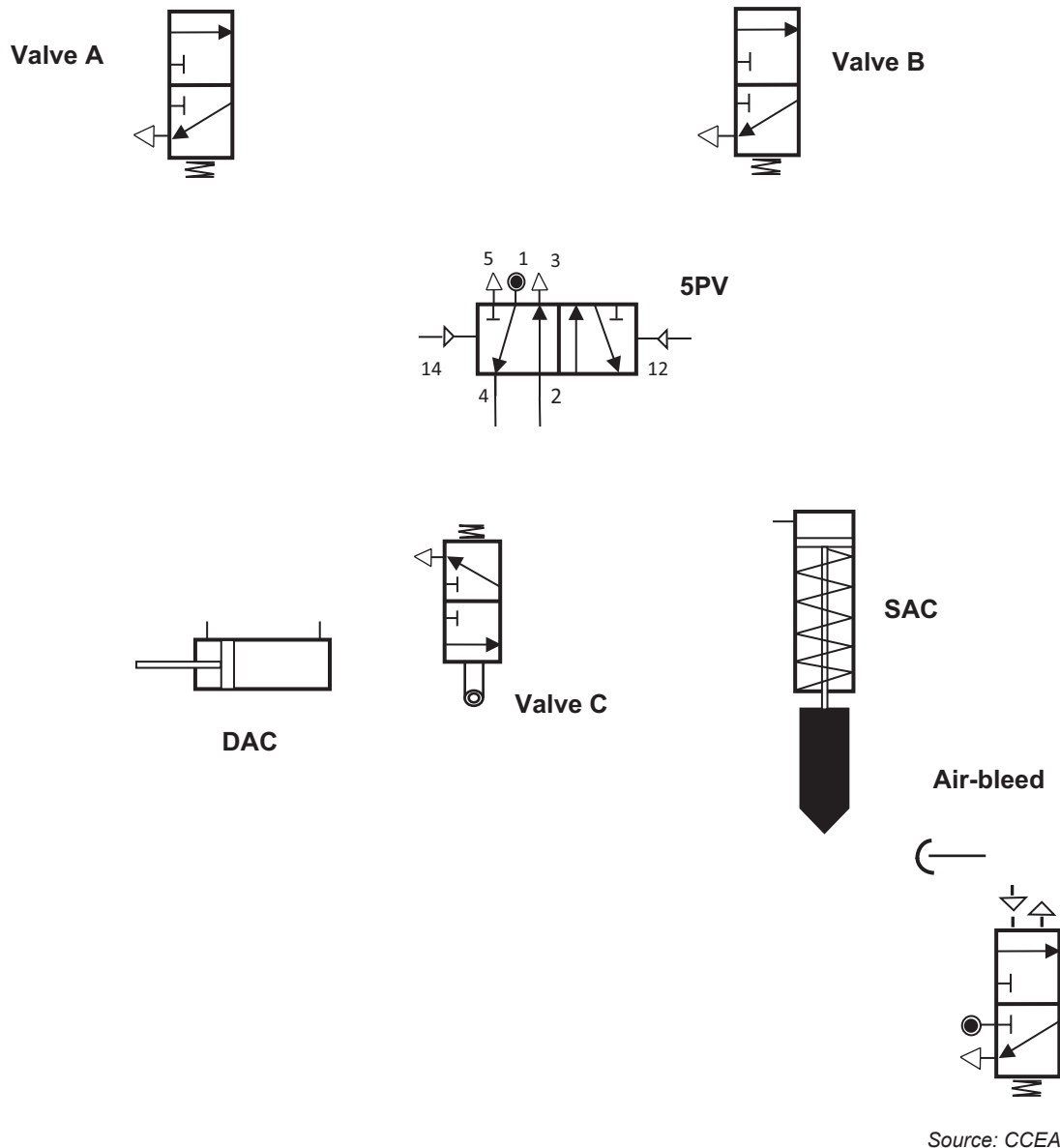
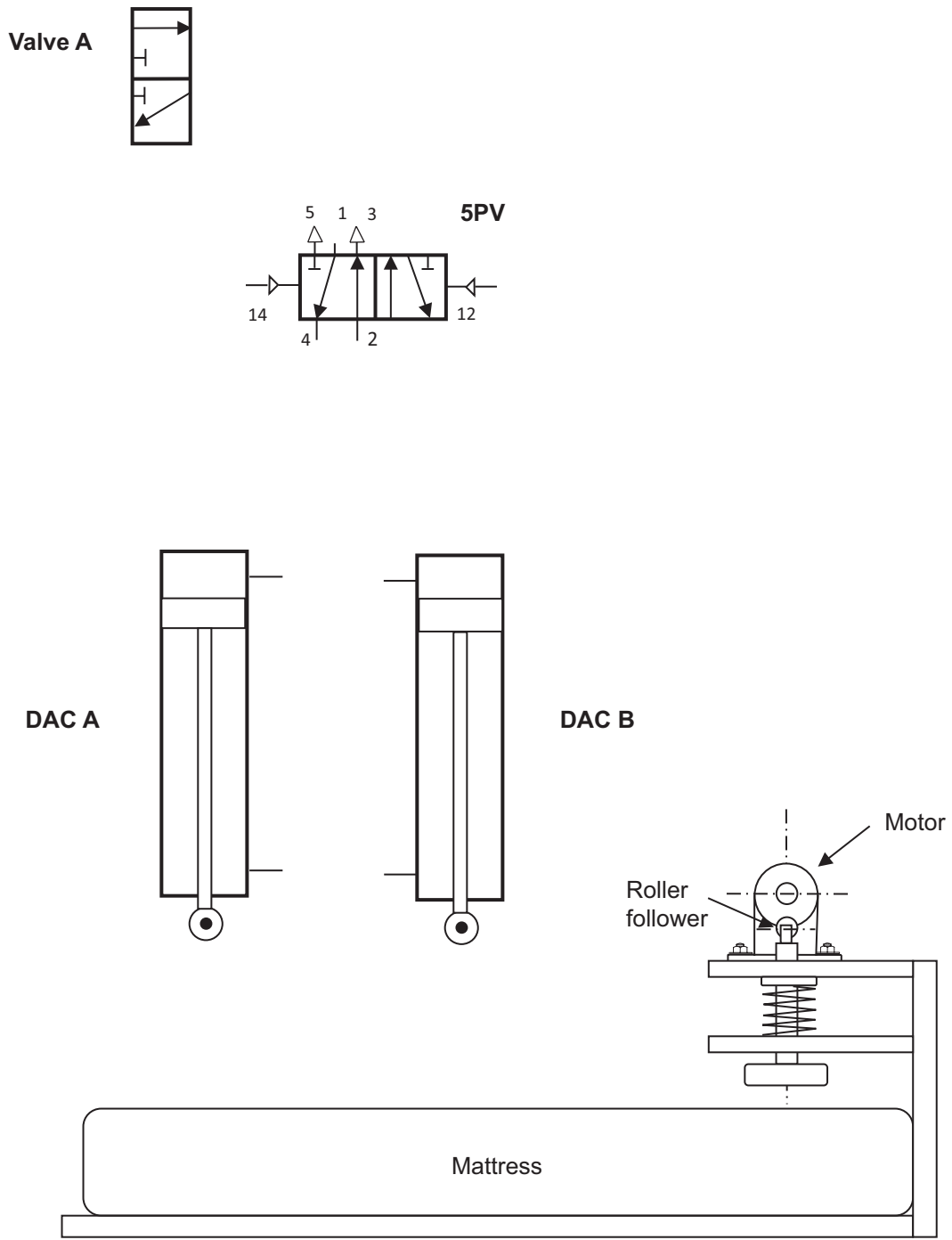

Fig. 12

[Turn over



4 Fig. 13 shows an incomplete prototype system used to test a mattress.



Source: CCEA

Fig. 13



Reciprocating and oscillating motion are commonly found in mechanical and pneumatic systems similar to the one shown in **Fig. 13**.

(a) Explain the difference between reciprocating and oscillating motion.

[2]

(b) In order to test one end of the mattress shown in **Fig. 13** an eccentric cam profile with a flat follower and a snail cam with a roller follower are to be trialled.

(i) On **Fig. 14** below, sketch the profile for an eccentric cam with a flat follower in order to activate the plunger.

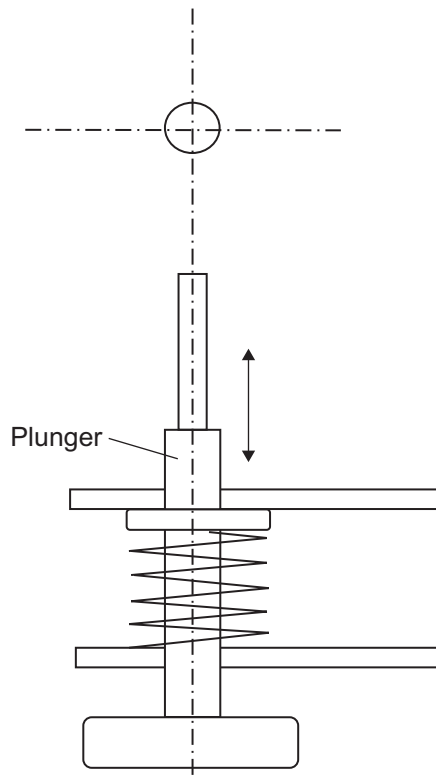

Source: CCEA

Fig. 14

[2]

[Turn over



(ii) With reference to the terminology of rise, dwell and fall, explain how the cam profile of a snail cam would affect the movement of the roller follower.

[2]



(c) An alternative method to test one end of the mattress is to use a pear shaped cam attached to the shaft of the motor in combination with a bell crank linkage.

On **Fig. 15** below, draw an annotated sketch of a bell crank linkage which will move the 10 kg weight up and down as the pear shaped cam rotates to move the roller follower.

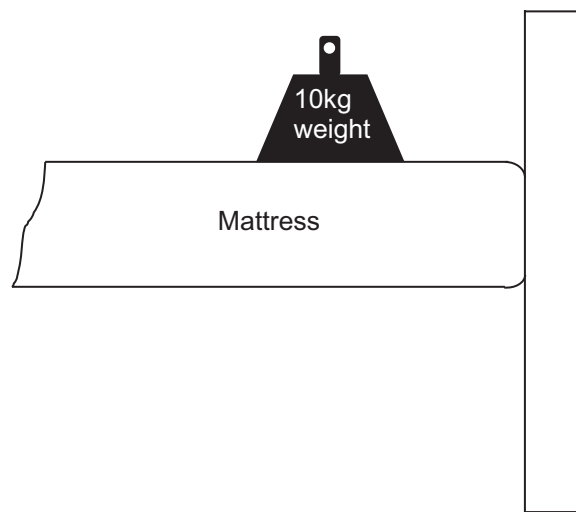
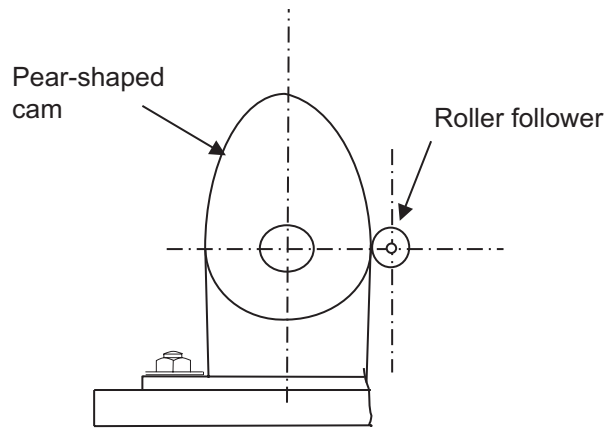

Source: CCEA

Fig. 15

[2]

[Turn over



(d) The pear shaped cam shown in **Fig. 15** is be attached to the shaft of the motor using a key and keyway. Using an annotated sketch, draw the main features of this method of attachment.

[3]

(e) The double acting cylinder DAC A shown in **Fig. 16** is supplied with an air pressure of 2 N/mm^2 , produces an instroke force of 706.5 N and has a piston rod diameter of 10 mm . Calculate the force produced during the outstroke of the double acting cylinder DAC A (as it goes positive making contact with the mattress). Assume $\pi = 3.14$.

Force _____ N [3]



(f) Complete **Fig. 16** below to create a fully automatic reciprocating circuit. Valve A will operate as an on/off valve controlling the supply of air. DAC A will outstroke as DAC B instrokes. A time delay will then automatically make DAC A instroke as DAC B outstrokes. Another time delay will then make DAC A outstroke as DAC B instrokes to create the fully automatic reciprocating circuit.

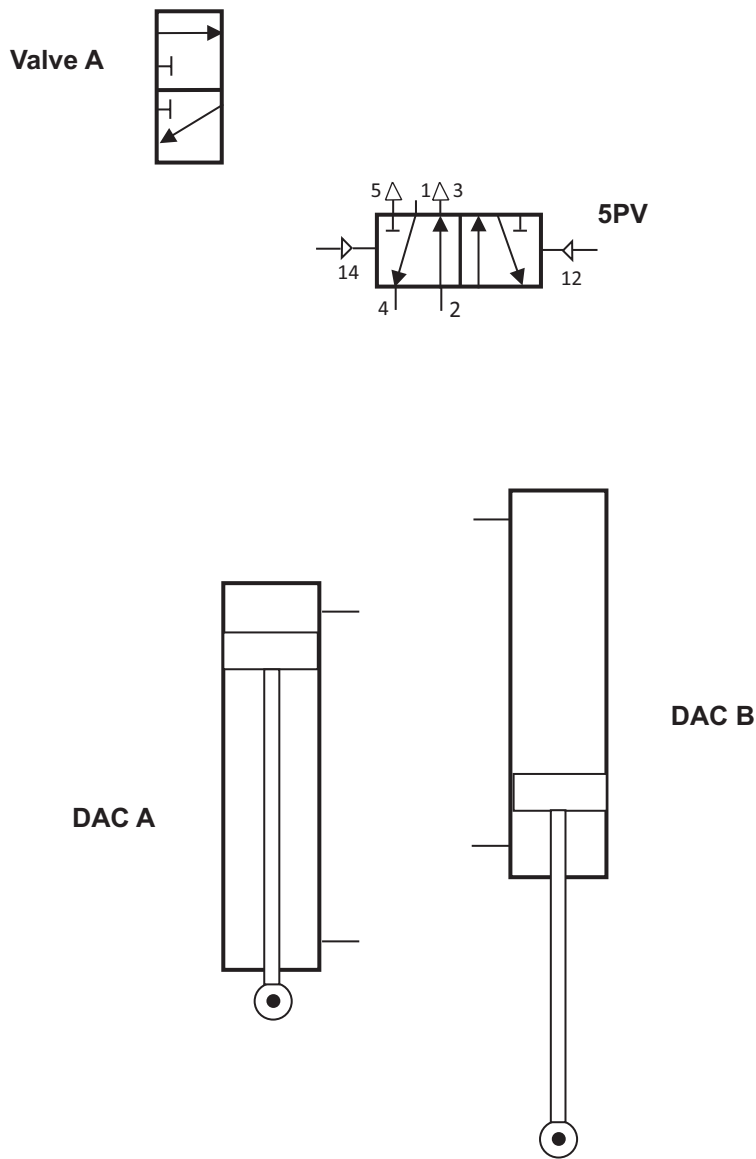

Source: CCEA

Fig. 16

[6]

[Turn over



Section C

Product Design

Answer **both** questions in this section.

- 5 **Fig. 17** below shows the situation that many shoppers face as they attempt to carry shopping bags from their local store. To assist the shopper, a bag carrier handle which is comfortable to use and could hold up to three shopping bags at any one time would be helpful.



Source: Principal Examiner

Fig. 17

A company that designs and manufactures a range of hand-held products is keen to develop a shopping bag carrier handle for consumers. When developing products for consumers the company wants to ensure that what they produce is fit for purpose.



(a) Briefly explain what is meant by the term fitness for purpose and give **two** reasons why the company would want to ensure that their products are fit for purpose.

Fitness for purpose

_____ [1]

Reason 1

_____ [1]

Reason 2

_____ [1]

(b) The company is considering either the use of one-off or batch production to produce the range of hand-held products.

Explain **two** reasons why one-off production is considered to be a more costly scale of production than batch production.

1. _____ [2]

2. _____ [2]

[Turn over



- (c) During company discussions it was suggested that the shopping bag holder could be packaged using cardboard. This cardboard could be die cut to give a desired profile.

With the use of an annotated sketch explain the process of die cutting which could be used to cut out a profile for packaging a product.

[4]

- (d) After discussing the intellectual property rights of the new design for the shopping bag holder the design team decided to apply for a trademark.

- (i) Briefly outline **two** characteristics associated with a trademark.

1. _____ [1]

2. _____ [1]

- (ii) Give **one** reason why it would be beneficial for the company to secure a trademark for the shopping bag holder.

_____ [1]



(e) With reference to **Fig. 18** below and with the aid of annotated freehand sketches complete the following using the blank A4 pro forma (**answer number 5(e)**) over the page:

An appropriate design of a hand-held shopping bag carrier handle which is suitable for a left or right-handed person and can allow the user to quickly attach and secure up to three filled shopping bags. State a suitable material for the shopping bag carrier handle and an appropriate manufacturing process if this is to be produced in large numbers. [6]



Source: Principal Examiner

Fig. 18

[Turn over



Pro forma answer page (answer no. 5 (e))

13429



36STE1228





BLANK PAGE

DO NOT WRITE ON THIS PAGE

(Questions continue overleaf)

13429

[Turn over



36STE1229

- 6 A company that produces car accessories is considering designing and manufacturing a range of car window flag holders. **Fig. 19** shows a drawing of a car window and door and the flag.

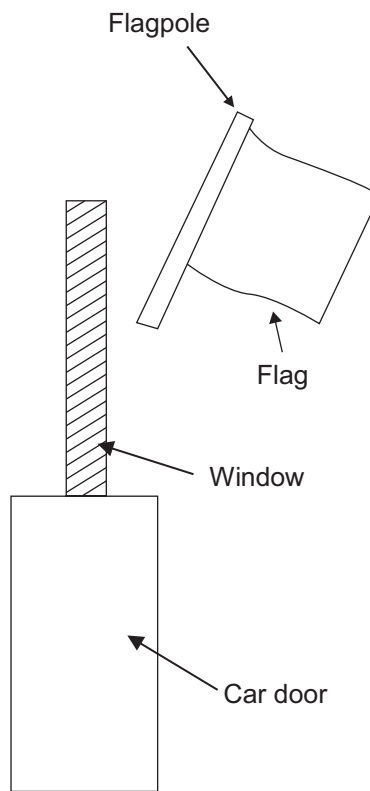

Source: CCEA

Fig. 19

- (a) (i) Outline what is meant by a design specification.

[1]

- (ii) Give **one** specific criterion that would need to be included in a manufacturing specification for a car window flag holder.

[1]



(b) When generating ideas for the car window flag holder the company considered used the technique of SCAMPER.

With reference to the letters S and A in the acronym SCAMPER explain how the meaning of the word created by each letter could help generate ideas.

S _____

_____ [2]

A _____

_____ [2]

(c) The company is considering manufacturing the car window flag holder from glass reinforced plastic (GRP).

Briefly outline **two** reasons why the company may want to use glass reinforced plastic (GRP) for the car window flag holder.

1. _____
_____ [1]

2. _____
_____ [1]

[Turn over



(d) The company uses concurrent engineering as the preferred method to organise the design and production for all the car accessory products they produce.

Briefly outline **two** characteristics associated with concurrent engineering.

1. _____
_____ [1]

2. _____
_____ [1]

(e) In an effort to make improvement the company is to focus more on quality control (QC) and quality assurance (QA) procedures.

Explain the difference between QA and QC procedures.

_____ [2]



(f) For the company, changes in fashion through miniaturisation and social changes have influenced the design of many products.

(i) With reference to a suitable product of your choice, explain the influence that miniaturisation has had on its design.

[2]

(ii) With reference to a social change of your choice, explain the influence that this has had on the design of a product of your choice.

[2]



- (g) The company plans to develop a plastic car window flag holder that can be quickly attached or removed from the window. **Fig. 20** shows a drawing of a car window and door and the flag.

Using the blank A4 pro forma (answer number **6(g)**) use detailed annotated sketches to produce **one** possible solution for the following:

An appropriate design for a car window flag holder which will securely hold either an 8 mm diameter flagpole or a 12 mm diameter flagpole at an angle of 60° as shown in **Fig. 20**. Your design should show how it is safely secured to the window of the car. [4]

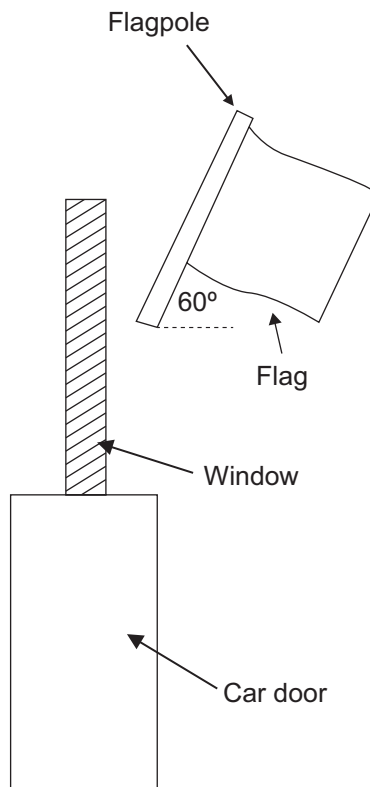

Source: CCEA

Fig. 20



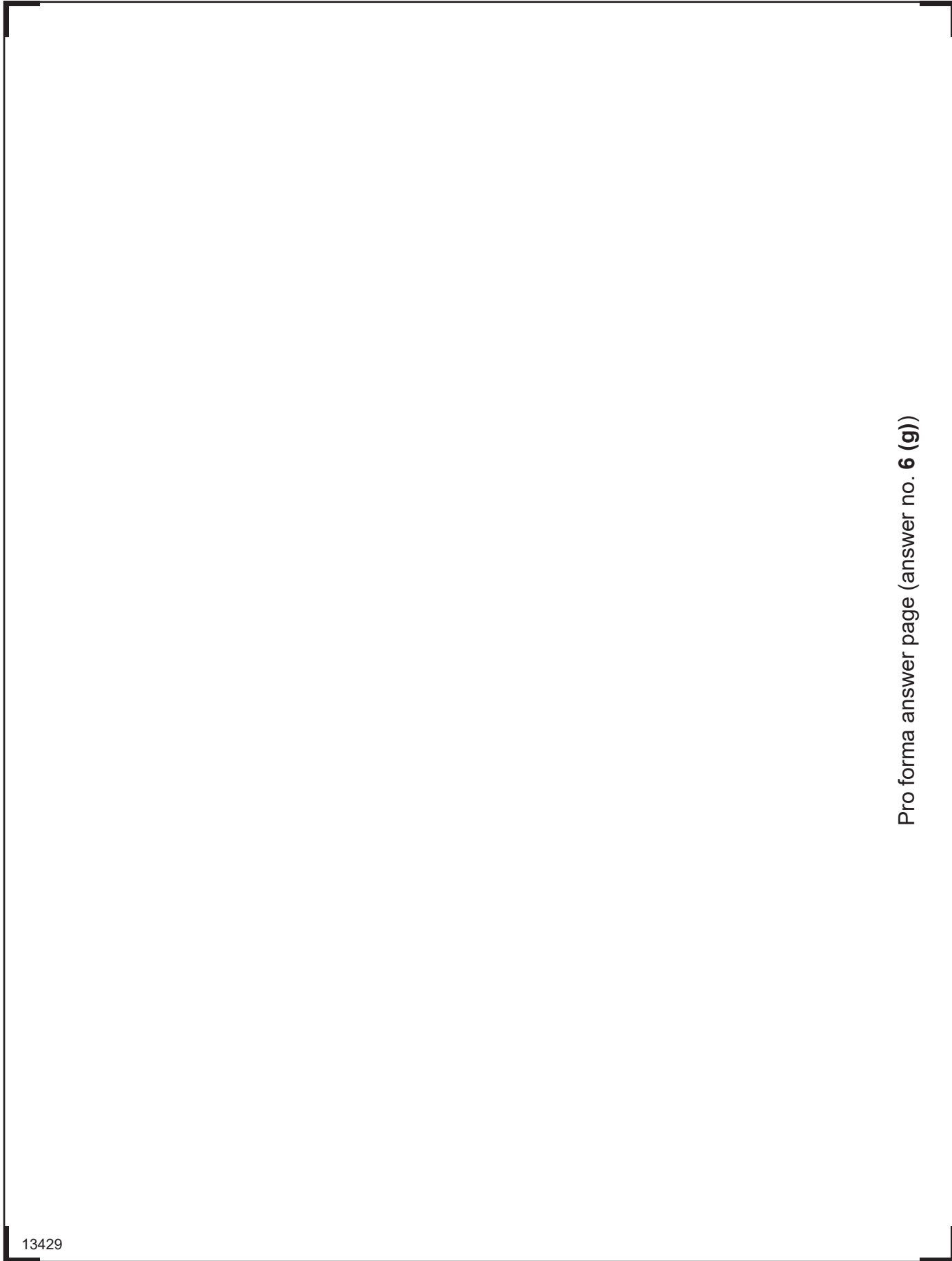

Pro forma answer page (answer no. 6 (g))

13429



36STE1235

THIS IS THE END OF THE QUESTION PAPER

DO NOT WRITE ON THIS PAGE

For Examiner's use only	
Question Number	Marks
1	
2	
3	
4	
5	
6	
Total Marks	

Examiner Number

Permission to reproduce all copyright material has been applied for.
In some cases, efforts to contact copyright holders may have been unsuccessful and CCEA will be happy to rectify any omissions of acknowledgement in future if notified.

STE12/11
277315



36STE1236